

SPX/SPZ SPARTAN HIGH POWER LUMINAIRE RANGE



Installation Guide

Zone 1 Variant - CML17ATEX1148 & IEC Ex CML17.0074

Zone 2 Variant - CML17ATEX4149 & IEC Ex CML17.0074

This installation guide provides instructions for installing the SPARTAN HP Highbay/ Floodlight series of explosion protected floodlights.

Overview



1. Safety Instructions
2. Installation
3. Maintenance
4. Technical Specification
5. Trouble Shooting

IMPORTANT INFORMATION

The SPARTAN HP series of explosion protected floodlights/highbay are specialist devices, certified for use in specific operating environments.

The units must be installed in accordance with these instructions, must be correctly certified for the specific operating environment and must be installed by suitably qualified personnel.

If you have any queries about the installation or the certification of the unit – please contact Raytec for immediate assistance and advice.

1. SAFETY INSTRUCTIONS

1. Read this leaflet carefully before commencing to install the SPARTAN unit and retain it for future use. Installation can only be carried out by suitably qualified personnel.
2. Check the certification to ensure that the Zone, mains supply, ambient temperature present and 'T' rating are suitable for the environment the unit is being installed in.
3. If the SPARTAN unit is to be installed in areas of high vibration, please consult with Raytec.
4. The SPARTAN unit housing is constructed from marine grade aluminium and toughened glass, gaskets are silicone sponge, black encapsulant and o rings are silicone rubber, inner domes on LEDs are polycarbonate. The end user must ensure that these materials are suitable for the environment the SPARTAN unit will be installed in; Zone 1 and Zone 2 Hazardous areas.
5. Check certification nameplate on side of floodlight/highbay to ascertain type of threaded cable entry on the luminaire. Select suitably certified ATEX/IEC Ex cable glands and stopper plugs, these must be parallel thread, have a minimum of 5 full thread engagement and be of a medium/fine tolerance to ISO965-1 and ISO965-3. The cable entry devices selected must maintain the IP rating of the luminaire
6. The incoming mains cable should not exceed a temperature rise of 20°C above the ambient conditions; select suitable cable.
7. To ensure the safety of the equipment, ensure that the 'flamepath' on Zone 1 variants are free from any corrosion. No repairs are possible to flameproof joints – if in doubt please consult the manufacturer.
8. External fasteners must have a yield strength of at least 600N/mm²
9. On Zone 1 variants the LED assembly contains no user serviceable parts, the luminaire must not be operated without all the individual LED polycarbonate covers in position, the IP66 rating must be maintained.

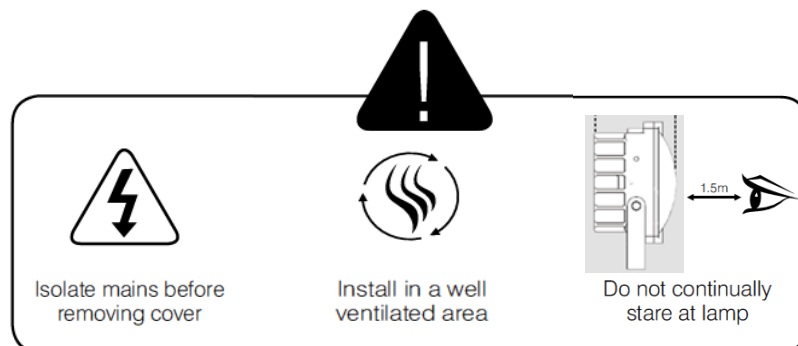

2. INSTALLATION

1. To meet the requirements of certification a **MINIMUM** of 2 fixing points must be used, the fixing points must be suitable for the conditions of use.
2. The line diagrams below are for guidance only – units may be mounted in any orientation

Mounting HP SPARTAN Unit – Floodlight Application

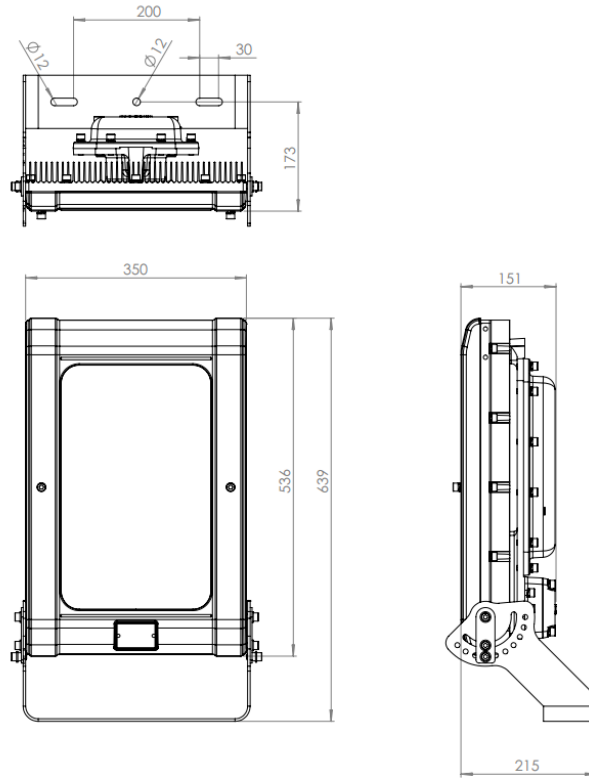

Mounting SPARTAN Unit – Highbay Application

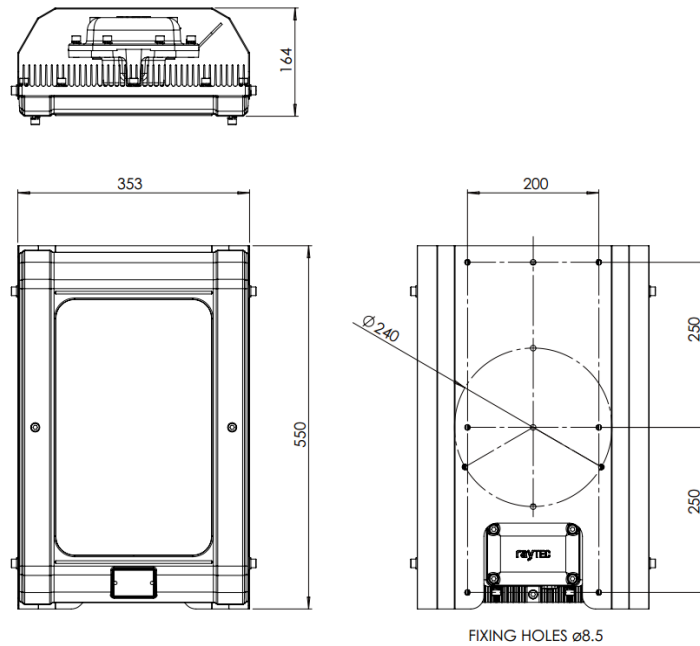

Typical wiring diagram

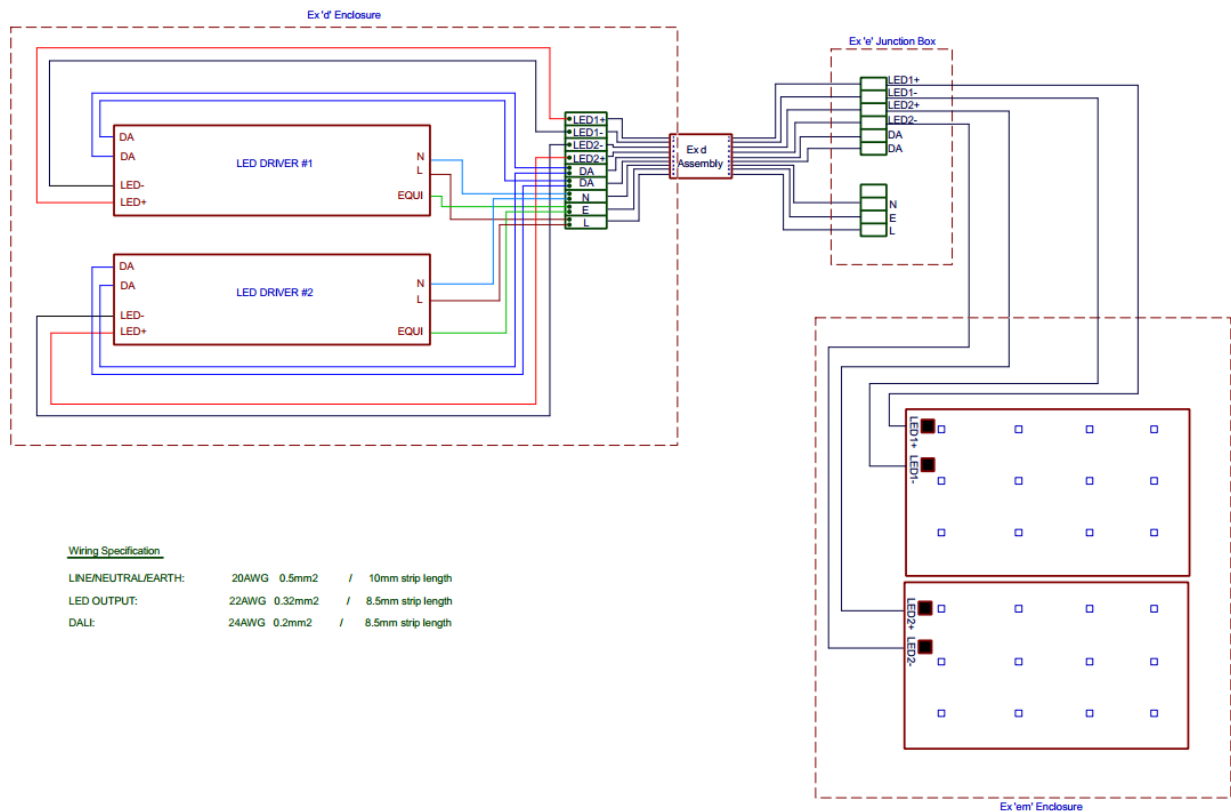

1. Wire the Mains cable into the terminal block. Provision has been made for this and identified as the E (Earth), L (Live), Ls (Live switched) and N (Neutral) terminals. There are two pairs of contacts for each of these to facilitate a mains cable that can be looped in and out of the unit. The Ls terminals on a standard unit are not electrically connected but allows them to be used on the same circuits as emergency floodlights.
2. Installer should earth the unit separately – an internal and external earth point are provided as standard
3. Connect wires to mains supply.
4. If the unit needs to be opened for any reason, isolate mains
5. All SPARTAN floodlights/highbay have terminal blocks suitable for looping 4mm² cable, only one cable should be connected to each terminal block connection
6. To use DALI/Dimming interface, connect the DALI terminals on the terminal block ensuring the correct polarity of DA+ and DA-

3. MAINTENANCE

1. It is essential that all SPARTAN units are maintained in accordance with the requirements of the EN60079-17 standard: (Electrical apparatus for explosive gas atmospheres – other than mines).
2. **IMPORTANT.** No modifications are permitted to the unit, all spare parts must be purchased from the manufacturer, unauthorized modifications or spare parts will invalidate certification and make the equipment dangerous.
3. Isolate the SPARTAN unit from the mains supply and allow to cool before carrying out any maintenance work.
4. The unit has 2 independent power supplies; in the event that a power supply needs to be replaced remove the flameproof cover to get access to the power supply. Remove the power supply from the mains terminals then remove LED red and black wires.
5. Disposal of packaging, SPARTAN units and old LED assemblies/power supplies should be carried out in accordance with national regulations.

4. TECHNICAL SPECIFICATION

	150W version	300W version
Input Voltage	150-264V AC or 150-264V DC see certification nameplate on product	
Consumption	150W	300W
Power Factor	>0.95	
Mains Frequency	50/60Hz	
IP Rating	IP66	
Weight (std)	22Kg	23Kg
Dimensions	See previous pages for line diagrams	
ATEX and IECEx Rating	See below	

PROTECTION/CERTIFICATION – ZONE 1 VARIANTS

CML17ATEX1148 or IEC Ex CML17.0074
 II 2 GD Ex db eb mb op is IIB + H2 T4
 Gb -50°C to +50°C
 Ex tb op is IIIC T104°C
 Db -50°C to +50°C
 IP66 150-264V AC/DC

PROTECTION/CERTIFICATION – ZONE 1 VARIANTS

CML17ATEX4149 or IEC Ex CML17.0074
 II 3 GD Ex nR ec mc op is IIC
 Gc -50°C to +50°C
 Ex tb op is IIIC T104°C
 Dc -50°C to +50°C
 IP66 150-264V AC/DC

5.TROUBLE SHOOTING

1. Ensure the two LED boards are correctly wired to terminal block.
White to White : Violet to Violet
2. Ensure Mains input is correctly connected.
3. Ensure Mains Input is turned on at the source
4. If LED panel fails to light is it possible to identify if problem is with LED panel or power supply by swapping LED cables to opposite power supply to help identify problem



DECLARATION OF CONFORMITY
WITH THE ATEX DIRECTIVE 2014/34/EU



Raytec Ltd. declares under our sole responsibility that the product(s) listed below conform with the relevant provisions of directive 2014/34/EU of 20th April 2016

Manufacturer	Raytec Ltd Unit 15, Wansbeck Business Park Rotary Parkway Ashington Northumberland NE63 8QW United Kingdom
Description of Equipment	Spartan range of High Power floodlights
Certificatin Body	CML New Port Road Ellesmere Port CH65 4LZ
Certificate numbers	CML17ATEX1148, CML17ATEX4149 or IEC Ex CML17.0074 Quality Assurance Notification Sira (0518)
Equipment Marking-	II 2 GD Ex db eb mb op is IIB + H2 T4 Gb -50°C to +50°C Ex tb op is IIIC T104°C Db -50°C to +50°C IP66 150-264V AC/DC or II 3 GD Ex nR ec mc op is IIC Gc -50°C to +50°C Ex tb op is IIIC T104°C Dc -50°C to +50°C IP66 150-264V AC/DC

Compliance with the Essential Health and Safety Requirements has been assessed by reference to the following standards -

IEC 60079-0 : 2012	IEC 60079-1 : 2014	IEC60079-7 : 2015
IEC 60079-15 : 2010	IEC 60079-18 : 2014	IEC60079-28 : 2015
IEC60079-31 : 2013		

And also 89/336/EEC – Electromagnetic Compatibility

Signed	<i>B. Thompson</i>
Name	Barry Thompson
Position	Director Hazardous Area Division

Dated

Serial number